

# The Influence of Digital Marketing, City Brand Communication, and Tourist Experience on the Effectiveness of Cirebon City Branding as a Tourism Destination

**Nurul Najma**

University Of Swadaya Gunung Jati, Cirebon

[nurul.122020048@ugj.ac.id](mailto:nurul.122020048@ugj.ac.id)

**Aang Curatman**

University Of Swadaya Gunung Jati, Cirebon

[aang.curatman@ugj.ac.id](mailto:aang.curatman@ugj.ac.id)

## Abstract

*The recovery of the tourism sector in the post-pandemic period requires city branding strategies that are not only well planned but also supported by empirical findings relevant to destination conditions. This study aims to examine the influence of digital marketing, city brand communication, and tourist experience on the effectiveness of city branding in Cirebon Regency as a tourism destination. The research applies a quantitative approach with an associative research design. Data were collected through questionnaires distributed to 156 tourist respondents and analyzed using the Structural Equation Modeling–Partial Least Squares (SEM-PLS) method. The results of the analysis indicate that digital marketing, city brand communication, and tourist experience each have a positive and significant effect on the effectiveness of city branding. Furthermore, the three variables simultaneously contribute significantly to explaining the variation in city branding effectiveness with a coefficient of determination of 75.7%. Tourist experience is proven to be the most dominant factor influencing city branding effectiveness, indicating the importance of synergy between digital strategies, brand consistency, and the quality of tourism experiences.*

**Keywords:** *digital marketing; city brand communication; tourist experience; city branding effectiveness.*

## A. INTRODUCTION

In recent years, attention toward regional tourism development and city branding strategies has increased significantly, driven by advances in digital technology and transformations in destination marketing strategies. Regional tourism plays an important role in supporting the local economy, both through job creation and through the preservation of cultural values and historical heritage within a region. Following the end of the global pandemic crisis, the number of tourist visits has shown a significant upward trend. Cirebon Regency can serve as an example of a region experiencing a tangible recovery in the tourism sector, as reflected in data published by the regional government ([Opendata.cirebonkab.go.id](http://opendata.cirebonkab.go.id)).

**Table 1. Number of Tourist Visits in Cirebon Regency, 2020–2024**

Year	Domestic Tourists
2020	504.484
2021	448.082
2022	682.944
2023	956.827

2024	1.091.575
------	-----------

*Source: Central Statistics Agency of Cirebon Regency*

Data from the Central Statistics Agency (BPS) of Cirebon Regency show that the total number of tourist visits in 2024 reached 1,091,575, representing the highest figure since the COVID-19 pandemic in 2020 and reflecting the end of the decline phase experienced by the tourism sector for several years. On the other hand, Cirebon Regency possesses a rich variety of tourism resources, including cultural and historical heritage sites, such as palace complexes, the Sunyaragi Cave site, diverse culinary tourism attractions, and developing tourism villages. These resources have strong strategic potential to be communicated through a sustainable and well-structured city branding approach.

In response to the increase in tourism activity, the regional government has also undertaken improvements in infrastructure to support tourism development (Radarcirebon.com). Amid increasingly competitive interregional competition, the effectiveness of city branding has become a major challenge for municipal and regency governments. The success of destination branding strategies largely depends on the integrated management of digital marketing strategies, city brand communication, and the quality of tourist experiences.

Research conducted by Confetto et al. (2023) emphasizes that the success of digital destination branding cannot be separated from the synergy between strategic brand communication and tourist experiences that mutually reinforce one another. In particular, digital marketing plays a central role as it enables rapid information dissemination, facilitates interaction with potential tourists, and allows more accurate measurement of promotional performance. Previous studies have found that the implementation of digital marketing positively affects tourist visit intentions (Aliyah et al., 2024; Saraswati et al., 2025). Additionally, user-generated content created by tourists influences destination image and visit intentions, increasing the likelihood of repeat visits (Aboalghanam & Alfraihat, 2025). Moreover, enjoyable and memorable tourism experiences can generate word-of-mouth recommendations and online reviews, which further strengthen the destination's brand image over time (Hikmawan Nasirudin & Subarjo, 2025).

Although numerous previous studies have discussed city branding and its influencing factors, most research still examines these variables partially, focusing only on aspects such as digital marketing or tourist experience in relation to visit intentions and tourist loyalty. Studies that integrate digital marketing, city brand communication, and tourist experience simultaneously within a single analytical framework to explain the effectiveness of city branding remain relatively limited (Confetto et al., 2023). As a result, a comprehensive understanding of the relative roles and interrelationships among these variables in shaping a city's brand has not yet been fully explored.

At the national level, city branding research tends to focus on cities with highly developed tourism sectors, while medium-sized destinations such as Cirebon Regency have received relatively limited quantitative investigation using integrated research models. In fact, local characteristics may significantly influence the effectiveness of the city branding strategies implemented (Astuti et al., 2025; Ningrum et al., 2023). Existing studies in Cirebon are mostly exploratory, qualitative, or descriptive in nature and conducted on a limited research scale (Ramadhanty et al., 2024; Risda & Candraningrat, 2025). Consequently, sufficient empirical evidence based on quantitative data to support strategic policy formulation regarding the influence of digital marketing, city brand communication, and tourist experience on city branding effectiveness remains lacking.

If this research gap continues to persist, efforts by local governments and tourism stakeholders to enhance city competitiveness through digital strategies may face significant obstacles. Without adequate empirical evidence, the formulation of digital marketing and city brand communication strategies may become unfocused and poorly coordinated, potentially leading to inefficient use of tourism promotional resources. Research conducted by Ramdan et al. (2025) shows that digital marketing approaches not grounded in empirical findings often fail to create emotional engagement among tourists and have limited impact on increasing visit intentions.

In response to these empirical limitations, this study proposes the development of an integrated conceptual model that combines digital marketing, city brand communication, and tourist experience as the main independent variables. This model is designed to examine these factors simultaneously while comparing their relative roles in shaping the effectiveness of city branding in Cirebon Regency. The primary objective of this research is to provide quantitative evidence explaining how these three variables influence the effectiveness of Cirebon's city branding as a tourism destination. Theoretically, the results of this study are expected to enrich the literature on destination marketing and city branding, particularly within the context of medium-sized destinations in Indonesia. Practically, the findings may

serve as a reference for the Cirebon Regency government and tourism stakeholders in formulating more targeted and data-driven regional tourism policies and strategies.

## **B. LITERATURE REVIEW**

### **Digital Marketing**

In this study, digital marketing is defined as variable X1, based on the theoretical framework of the digital marketing funnel or AIDA model. The theory proposed by Chaffey and Ellis-Chadwick (2019) in (Bilková, 2021) conceptualizes digital marketing as a form of marketing communication that utilizes digital platforms and internet networks to build interaction and influence consumer behavior through several stages: awareness, interest, desire, and action. These stages are dynamic and continue to evolve alongside changes in consumer behavior within the digital environment.

Various empirical findings support the relevance of this theory in the tourism context. Research conducted by Yang et al. (2019) revealed that the use of social media and electronic word-of-mouth (e-WOM) significantly contributes to improving destination image and tourists' travel intentions. This indicates that digital marketing plays an important role in building public awareness and engagement with a city brand. Furthermore, studies such as Rodrigues et al. (2023) emphasize the importance of strategic digital communication in strengthening destination branding.

Moreover, this theoretical framework highlights that the effectiveness of digital marketing strategies does not solely depend on the use of digital media but also on the consistency of brand messages and the ability of Destination Management Organizations (DMOs) to establish fast and interactive two-way communication with potential tourists. Therefore, this theory is relevant for explaining the mechanism through which digital marketing, as the independent variable (X1), influences the effectiveness of city branding (Y) within the framework of Destination Marketing Management (DMM).

### **City Brand Communication**

In this study, city brand communication is positioned as variable X2 and is conceptually grounded in place identity theory. This theory, originally introduced by Proshansky (1978) and further developed by Peng et al. (2020), views place identity as an essential component of an individual's self-identity formed through accumulated experiences, values, beliefs, emotions, and behavioral tendencies associated with a particular location. Consequently, city brand communication serves as a strategic instrument for shaping symbolic meaning and emotional attachment between tourists and a destination.

Empirical evidence also supports the relevance of this theory in tourism research. A study conducted by Rodrigues et al. (2023) found that transparent and consistent communication regarding destination sustainability initiatives significantly influences tourist preferences. This finding suggests that clarity and consistency of communication are essential elements in conveying the unique characteristics and fundamental values of a destination.

Therefore, this theoretical framework is used to explain the mechanism through which city brand communication as an independent variable (X2) influences the effectiveness of city branding as the dependent variable (Y) in the context of urban destination marketing management (DMM).

### **Tourist Experience**

In this study, tourist experience is defined as variable X3, based on the theoretical concept of the experience economy. According to Pine and Gilmore (1999) in (Panduputri & Novani, 2021), tourist experience represents the subjective perception of tourists formed through direct engagement with various elements of a destination and carries personal meaning. This perception emerges from tourists' interactions with the destination environment, including service quality, socio-cultural conditions, interactions with local communities, and physical facilities.

The experience economy theory classifies tourist experiences into four main dimensions: Esthetics, Education, Entertainment, and Escapism, which reflect the depth and quality of experiences perceived by tourists during their visit. These dimensions highlight how tourism experiences go beyond functional consumption and become meaningful emotional interactions with the destination.

Furthermore, this concept emphasizes that memorable and emotionally meaningful tourism experiences act as tangible representations of the city's brand promise. Such experiences contribute to strengthening destination brand associations in the minds of tourists. Therefore, this theory is relevant for explaining how tourist experience as variable X3 influences the effectiveness of city branding (Y) within the framework of urban destination marketing management (DMM).

### **City Branding Effectiveness**

In this study, city branding effectiveness is defined as the dependent variable (Y), based on the theoretical concept of destination brand equity. This concept was originally developed by Aaker (1991) and later expanded within the context of tourism destinations by Ahn (2022). It conceptualizes city

branding effectiveness as the ability of a destination brand to create and deliver added value for the destination.

This added value is reflected through several key dimensions, including brand awareness, brand associations, brand loyalty, and perceived quality. These elements collectively determine how a destination brand is recognized, perceived, and valued by tourists.

Furthermore, this concept highlights that the success of a city brand is characterized by its ability to create clear differentiation from competing destinations while delivering both emotional and functional benefits to the targeted market segments. Based on this perspective, destination brand equity theory serves as the theoretical foundation for explaining how city branding effectiveness as the dependent variable (Y) reflects the overall success of destination marketing management (DMM) strategies.

### **Hypotesis**

**Figure. 1 Conceptual Framework**

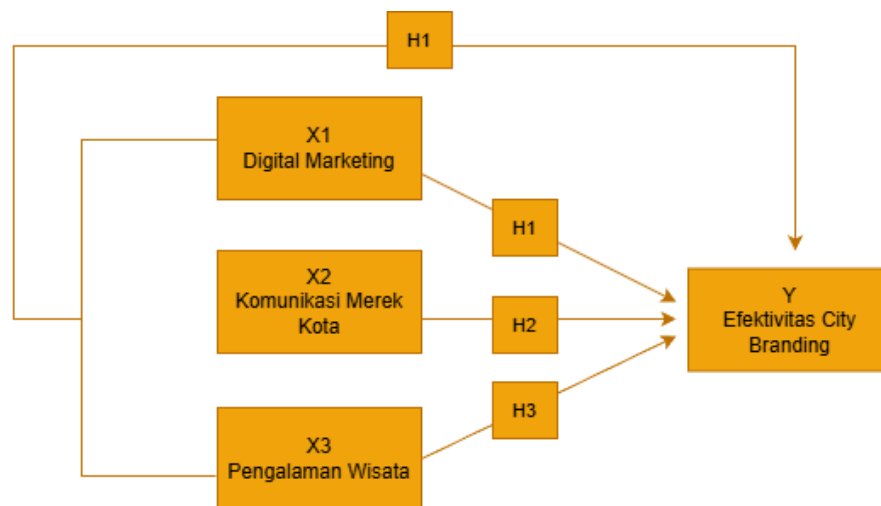

### **C. METHODOLOGY OF RESEARCH**

This study employed a quantitative approach with an associative research design to examine the relationships between the independent variables and the dependent variable. The independent variables consist of digital marketing (X1), city brand communication (X2), and tourist experience (X3), while the dependent variable is city branding effectiveness (Y), as suggested by Sugiyono (2013). The research population includes all tourists who are currently visiting or have previously visited tourism destinations in Cirebon Regency within a certain period. Based on data from the tourism statistics of Cirebon Regency, the total number of domestic tourist visits in 2024 reached 1,097,029, which was used as the population size (N). The sample size was determined using the Slovin formula with a margin of error of 8%, resulting in a minimum required sample of 156 respondents. The sampling technique used in this study was purposive sampling, with criteria including tourists who have visited at least one tourism destination in Cirebon Regency, have searched for tourism information about Cirebon through digital platforms, and are at least 18 years old.

The data used in this study consisted of primary and secondary data. Primary data were collected through a structured questionnaire distributed to respondents using a five-point Likert scale ranging from 1 (strongly disagree) to 5 (strongly agree). The questionnaire items were developed based on theoretical indicators derived from previous studies and relevant literature. The questionnaire measured respondents' perceptions of the four variables: digital marketing (X1), city brand communication (X2), tourist experience (X3), and city branding effectiveness (Y). Examples of measurement items include statements related to the discovery of tourism information about Cirebon through social media, the consistency of promotional messages representing Cirebon's cultural uniqueness, the authenticity and memorability of tourism experiences, and the perception of Cirebon's tourism image encouraging revisit intentions or recommendations. To ensure the quality of the research instrument, validity testing was conducted using Confirmatory Factor Analysis (CFA) within the SEM-PLS framework, where indicators

were considered valid if the Outer Loading  $\geq 0.70$  and Average Variance Extracted (AVE)  $\geq 0.50$ . Meanwhile, reliability testing was conducted using Cronbach's Alpha and Composite Reliability (CR), with a threshold value of  $\geq 0.70$  to confirm internal consistency.

The data analysis in this study was conducted using Structural Equation Modeling (SEM) with the Partial Least Squares (PLS) approach, which is considered effective for testing complex causal relationships with predictive objectives. The analysis procedure consisted of several stages. First, descriptive statistical analysis was performed to describe the characteristics of respondents, including gender, age, occupation, domicile, types of tourism destinations visited, and the main sources of information about Cirebon tourism. Second, the measurement model (outer model) was evaluated through validity and reliability testing to ensure that the indicators accurately measured the latent constructs. Third, the structural model (inner model) was assessed using several indicators, including the coefficient of determination ( $R^2$ ) to measure the explanatory power of the independent variables on the dependent variable, F-square ( $f^2$ ) to evaluate the contribution of each independent variable, and predictive relevance ( $Q^2$ ) using the blindfolding technique to assess the predictive capability of the model. Fourth, hypothesis testing was conducted to examine the proposed research hypotheses (H1, H2, H3, and H4). Finally, the statistical results were interpreted and discussed by linking them with relevant theoretical frameworks, including the concepts proposed by Aaker, Proshansky, and Pine & Gilmore, as well as previous empirical studies. The research was conducted online in Cirebon Regency during December 2025 to January 2026, covering instrument preparation, questionnaire distribution, and data processing stages.

**D. RESULT AND DISCUSSION**

**Data Processing**

**Table. 1 Respondent Characteristics**

Characteristics	Category	Frequency	Percentage (%)
<b>Gender</b>	Male	70	44.9
	Female	86	55.1
<b>Total</b>		156	100
<b>Age (Years)</b>	<20 Years	39	25.0
	20-30	109	69.9
	31-40	8	5.1
<b>Total</b>		156	100
<b>Occupation</b>	Student	116	74.4
	Government Employee	7	4.5
	Private Employee	25	16.0
	Entrepreneur	8	5.1
<b>Total</b>		156	100
<b>Domicile</b>	Cirebon	52	34.0
	Indramayu	51	32.7
	Majalengka	17	4.5
	Kuningan	4	2.6
	Bandung	12	7.7
	Bogor	2	1.3
	Purwakarta	3	1.9
	Tasikmalaya	1	0.6
	Depok	2	1.3
	Karawang	1	0.6
	Bekasi	1	0.6
	Jakarta	8	5.1
	Tangerang	2	1.3
	Brebes	1	0.6
	Purwokerto	2	1.3
	Yogyakarta	1	0.6
	Surabaya	2	1.3
<b>Domicile</b>	Bali	1	0.6

	Kalimantan	1	0.6
	Aceh	1	0.6
<b>Total</b>		156	100
<b>Type of Tourism Destination Visited</b>	Cultural/Historical Tourism	126	65.6
	Nature Tourism	19	9.9
	Culinary Tourism	17	8.9
	Man-made Tourism	15	7.8
<b>Total</b>		156	100
<b>Main Source of Tourism Information in Cirebon</b>	Social Media	114	73.1
	Official Website	1	0.6
	Family/Friends Recommendation	41	26.3
	<b>Total</b>		156

Based on Table 4.1, the majority of respondents were female (55.1%) and aged 20–30 years (69.9%), indicating dominance by a productive and digitally active age group. Most respondents were students (74.4%), with the largest share coming from Cirebon (34%) and Indramayu (32.7%), although respondents from other regions were also represented. In terms of tourism preferences, most had visited cultural or historical destinations (65.6%), reflecting Cirebon’s strong cultural tourism image. Additionally, social media (73.1%) was identified as the main source of tourism information, highlighting the important role of digital marketing in supporting Cirebon’s city branding.

**Table.2 Convergent Validity Test Results**

<b>Variable</b>	<b>Indicator</b>	<b>Outer Loading</b>
<b>Digital Marketing (X1)</b>	DM1	0.781
	DM2	0.812
	DM3	0.846
	DM4	0.798
	DM5	0.805
<b>City Brand Communication (X2)</b>	CBC1	0.824
	CBC2	0.836
	CBC3	0.851
	CBC4	0.809
<b>Tourist Experience (X3)</b>	TE1	0.842
	TE2	0.855
	TE3	0.821
	TE4	0.833
<b>City Branding Effectiveness (Y)</b>	CBE1	0.864
	CBE2	0.879
	CBE3	0.841
	CBE4	0.852

The results of the convergent validity test indicate that all indicators for each research variable have loading factor values  $\geq 0.70$  and Average Variance Extracted (AVE) values  $> 0.50$ . This condition shows that the indicators used are able to adequately explain the latent constructs and have a strong level of correlation with the variables they measure.

Conceptually, convergent validity reflects the extent to which indicators within the same construct are correlated and truly represent the same concept. The high loading factor values indicate that each indicator contributes significantly to forming the variables of Digital Marketing, City Brand Communication, Tourist Experience, and City Branding Effectiveness. This demonstrates that the questionnaire items were developed in accordance with the theoretical dimensions of each variable.

Furthermore, the AVE values exceeding the minimum threshold indicate that most of the variance in the indicators can be explained by the latent constructs rather than by measurement error. Therefore, the research instrument is not only capable of measuring the variables accurately but also demonstrates good measurement quality. The fulfillment of convergent validity confirms that the measurement model (outer model) in this study is appropriate to be used in the subsequent structural model analysis stage.

**Figure. 2 Outer Model**

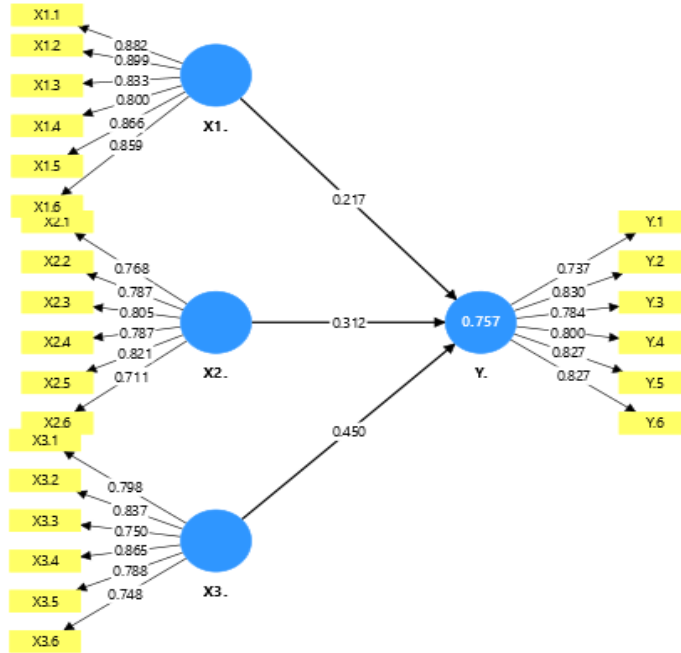

**Table. 3 Discriminant Validity Test Results**

Variable	X1	X2	X3	Y
Digital Marketing (X1)				
City Brand Communication (X2)	0.754			
Tourist Experience (X3)	0.625	0.821		
City Branding Effectiveness (Y)	0.748	0.893	0.897	

The results of the discriminant validity test indicate that the square root of the AVE value for each variable is greater than the correlations between that variable and other variables in the model. This finding suggests that each construct possesses unique characteristics and is capable of distinguishing itself from other constructs within the research model.

Discriminant validity is important to ensure that a variable does not excessively measure the same concept as other variables. In the context of this study, the results show that Digital Marketing, City Brand Communication, Tourist Experience, and City Branding Effectiveness are related constructs but still maintain clear conceptual boundaries. In other words, although these variables interact in shaping city branding, each represents a distinct dimension.

With discriminant validity being satisfied, it can be concluded that respondents are able to differentiate between the experiences they directly encounter, the city brand messages they receive, and the digital marketing strategies implemented. This strengthens the reliability of the measurement model and reduces the potential bias caused by overlapping constructs.

**Table. 4 Reliability test**

Variable	Cronbach's Alpha	Composite Reliability (rho_a)	Composite Reliability (rho_c)
Digital Marketing (X1)	0.928	0.933	0.943
City Brand Communication (X2)	0.871	0.873	0.903
Tourist Experience (X3)	0.886	0.889	0.913
City Branding Effectiveness (Y)	0.888	0.890	0.915

The reliability test results indicate that all variables have Cronbach’s Alpha and Composite Reliability values above 0.70, which reflects a high level of internal consistency. High reliability values suggest that the indicators within each variable consistently measure the same concept.

Instrument reliability reflects the stability and dependability of measurement. In this study, the high reliability values indicate that respondents provided relatively consistent responses to the indicators within each construct. Therefore, the research instrument can be considered reliable for measuring respondents’ perceptions regarding digital marketing, city brand communication, tourist experience, and city branding effectiveness.

In addition, the strong reliability results also indicate that the research instrument has minimal measurement error. This strengthens the confidence that the relationships among variables identified in the structural analysis stage truly reflect the empirical conditions observed in the field.

**Table. 5 Coefficient of Determination (R<sup>2</sup>)**

Variabel	R-square	R-square adjusted
City Branding Effectiveness	0.757	0.752

The coefficient of determination (R<sup>2</sup>) value of 0.757 indicates that the combination of Digital Marketing, City Brand Communication, and Tourist Experience variables is able to explain 75.7% of the variation in City Branding Effectiveness. Based on the research results, the fourth hypothesis (H4), which states that Digital Marketing, City Brand Communication, and Tourist Experience simultaneously influence City Branding Effectiveness, is accepted. The relatively high R<sup>2</sup> value indicates that these three independent variables collectively play a strong role in shaping the city branding effectiveness of Cirebon Regency.

**Table. 6 F-Square**

	X1	X2	X3	Y
X1				0.054
X2				0.225
X3				0.281
Y				

Based on the f-square results, the effect of variable X1 on Y has an f-square value of 0.054. This indicates that X1 exerts a small effect on Y, meaning that although X1 contributes to explaining Y, its contribution is relatively limited compared to other variables in the model. Meanwhile, variable X2 has an f-square value of 0.225 on Y, indicating a medium effect. This result suggests that X2 plays a fairly significant role in influencing Y and provides a meaningful contribution to increasing the value of Y.

**Table.7 Relevance (Q<sup>2</sup>)**

Variabel	Q <sup>2</sup> predict	Relevan
<i>Efektivitas City Branding (Y)</i>	0.724	0.542

The predictive relevance test results show a Q<sup>2</sup> value greater than zero, indicating that the research model has good predictive capability. This means the constructed model can effectively predict city branding effectiveness based on the independent variables used. A high Q<sup>2</sup> value suggests that the model not only demonstrates statistical fit but also has practical relevance in explaining and predicting city branding phenomena. Therefore, this study model can serve as a basis for decision-making in developing city branding strategies grounded in digital marketing, city brand communication, and enhanced tourist experiences.

**Tabel 4.7 Uji Hipotesis**

	Original sample (O)	Sample mean (M)	Standard deviation (STDEV)	T statistics ( O/STDEV )	P values
X1. -> Y.	0.217	0.224	0.085	2.550	0.011

X2. -> Y.	0.312	0.299	0.113	2.772	0.006
X3. -> Y.	0.450	0.455	0.117	3.840	0.000

**Discussion**

**The Effect of Digital Marketing on City Branding Effectiveness (H1)**

The hypothesis testing results indicate that Digital Marketing has a positive and significant effect on City Branding Effectiveness, evidenced by a t-statistic of 2.550 (>1.96), a p-value of 0.011 (<0.05), and a path coefficient of 0.217, confirming that H1 is accepted. This finding demonstrates that the more optimally digital marketing is implemented in promoting tourism in Cirebon Regency, the more effective the city branding perceived by tourists. Digital marketing through social media and other digital platforms enhances destination visibility, expands the reach of information, and fosters positive perceptions of city identity. Empirically, respondents reported that digital channels facilitated access to tourism information and created favorable first impressions, positioning digital marketing as the primary gateway for shaping city image prior to direct experience. These results align with Ramkissoon (2023) in *Acta Psychologica* (Scopus Q1), which emphasizes the significant relationship between digital marketing, social media, and tourist perceptions and behaviors toward destinations.

**The Effect of City Brand Communication on City Branding Effectiveness (H2)**

The analysis reveals that City Brand Communication positively and significantly influences City Branding Effectiveness, with a t-statistic of 2.772 (>1.96), a p-value of 0.006 (<0.05), and a path coefficient of 0.312, supporting the acceptance of H2. Clear, consistent, and comprehensible city brand communication strengthens the image and identity of Cirebon as a tourist destination. It facilitates tourists' understanding of the city's character, values, and uniqueness, leading to a stronger, more memorable city image. Empirically, respondents acknowledged that promotional messages, tourism narratives, and city symbols effectively conveyed Cirebon's identity as a cultural and historical tourism destination. This finding is consistent with Suraya (2024), who asserts that consistent city brand communication significantly influences destination image formation, and Marta et al. (2022), highlighting that successful city branding relies on the city's ability to communicate its identity and brand values effectively.

**The Effect of Tourist Experience on City Branding Effectiveness (H3)**

Hypothesis testing indicates that Tourist Experience has a positive and significant effect on City Branding Effectiveness, with a t-statistic of 3.840 (>1.96), a p-value of 0.000 (<0.05), and a path coefficient of 0.450, confirming H3. This result suggests that direct tourist experiences constitute the most dominant factor in shaping Cirebon's city branding effectiveness. Positive experiences encompassing comfort, destination uniqueness, and cultural-historical impressions strengthen the city's image and increase the likelihood of tourists recommending the destination. Empirically, respondents reported that their experiences in Cirebon left a profound impression, which contributed significantly to positive perceptions of the city. These findings are consistent with Pine and Gilmore's (1999) Experience Economy framework and reinforced by Chen (2022) in *Tourism Management* (Scopus Q1), which confirms that tourist experience significantly affects destination image and loyalty.

**Simultaneous Effect of Digital Marketing, City Brand Communication, and Tourist Experience on City Branding Effectiveness (H4)**

Structural model analysis demonstrates that Digital Marketing, City Brand Communication, and Tourist Experience jointly have a significant effect on City Branding Effectiveness, as evidenced by an R<sup>2</sup> of 0.757. This indicates that the majority of variance in city branding effectiveness can be explained by these three integrated variables. The results highlight that city branding effectiveness is a multidimensional outcome rather than the effect of a single variable. Digital marketing broadens information reach and shapes initial tourist perceptions, city brand communication reinforces understanding of destination identity and characteristics, and tourist experience serves as the final evaluative component determining whether the constructed image is genuinely perceived.

These findings support the notion that sustainable city branding requires alignment between communicated messages and the reality experienced by tourists. When digital marketing and city brand communication are not accompanied by adequate tourist experience, the perceived brand credibility is weakened. Conversely, positive tourist experiences enhance brand messages and increase the destination's credibility. Therefore, the success of Cirebon Regency's city branding is significantly influenced by the synergy of digital promotion strategies, consistent city brand communication, and high-quality tourist experiences, which together form an inseparable unit in building a strong, credible, and competitive city brand.

## **E. CONCLUSION**

Based on the data analysis and discussion of the effects of digital marketing, city brand communication, and tourist experience on city branding effectiveness, several conclusions can be drawn. First, digital marketing has a positive and significant impact on city branding effectiveness. The findings indicate that the use of digital platforms, particularly social media, plays a critical role in enhancing destination exposure, expanding information reach, and shaping initial positive perceptions of Cirebon Regency. Digital marketing serves as the initial medium for forming the city's image before tourists experience the destination firsthand.

Second, city brand communication also demonstrates a significant positive effect on city branding effectiveness. Consistent, clear, and culturally contextualized brand messages strengthen Cirebon's identity and image as a promotional destination. The effectiveness of city brand communication relies on the destination's ability to convey authentic and well-targeted messages to tourists, ensuring that cultural and historical values are communicated effectively and memorably.

Third, tourist experience emerges as the most dominant factor influencing city branding effectiveness. Direct experiences of tourists are crucial for shaping the city's image, reinforcing brand associations, encouraging word-of-mouth recommendations, and increasing the likelihood of repeat visits. Overall, digital marketing, city brand communication, and tourist experience collectively explain a substantial portion of the variation in city branding effectiveness in Cirebon, as reflected in the high coefficient of determination. These results confirm that effective city branding management requires an integrated approach, combining digital strategies, consistent brand communication, and high-quality tourism experiences. Accordingly, the study recommends that local government, tourism stakeholders, and destination managers optimize digital marketing efforts, maintain consistent brand messaging, and enhance tourist experiences, while future research could expand the model by including variables such as tourist satisfaction, loyalty, and destination image to further enrich city branding studies.

## **F. REFERENCES**

- Aboalganam, K. M., & Alfraihat, S. F. (2025). The Impact of User-Generated Content on Tourist Visit Intentions : The Mediating Role of Destination Imagery. 2023(2024).
- Ahn, Y. (2022). City Branding and Sustainable Destination Management. contribution 5, 7–10.
- Aliyah, K., Kisworo, B., Miraj, S., Gupta, S., Semarang, U. N., Muhammadiyah, U., & Utara, M. (2024). Available online at : <http://journal.uny.ac.id/index.php/jppm> JPPM ( Jurnal Pendidikan dan Pemberdayaan Masyarakat ) The Effect of Digital Marketing Through Social Media and Tourism Attractiveness on Visitor Interest. 11(1), 26–38.
- Astuti, W., Natsir, M., & Elmas, M. (2025). Exploring the Paradoxes of Tourism: How Memorable Experiences, City Branding, and Destination Image Influence Revisit Intentions? *Jurnal Riset Bisnis Dan Manajemen*, 18(1), 95–105. <https://doi.org/10.23969/jrbm.v18i1.17579>
- Bílková, R. (2021). Digital marketing communication in the age of globalization. *SHS Web of Conferences*, 129, 06002. <https://doi.org/10.1051/shsconf/202112906002>
- Chen, C., Su, C. J., & Chen, M. (2022). Are ESG-committed hotels financially resilient to the COVID-19 pandemic? An autoregressive jump intensity trend model. *Tourism Management*, 93(March), 104581. <https://doi.org/10.1016/j.tourman.2022.104581>
- Confetto, M. G., Conte, F., Palazzo, M., & Siano, A. (2023). Digital destination branding: A framework to define and assess European DMOs practices. *Journal of Destination Marketing and Management*, 30. <https://doi.org/10.1016/j.jdmm.2023.100804>
- Hikmawan Nasirudin & Subarjo. (2025). Pengaruh Daya Tarik Wisata , Pengalaman Wisatawan , dan Kepuasan. *Journal of Humanities Education Management Accounting and Transportation*, 2(1), 113–123.
- Kamyabi, M., Özgüt, H., & Ahmed, J. N. (2025). Sustaining Digital Marketing Strategies to Enhance Customer Engagement and Brand Promotion: Position as a Moderator. *Sustainability (Switzerland)*, 17(7), 1–17. <https://doi.org/10.3390/su17073270>
- Marta, R., Havifi, I., & Safril, F. A. (2022). Model Komunikasi City Branding Pariwisata Sumatera Barat Di Tengah Adaptasi Kebiasaan Baru Pandemi Covid-19. 15(1), 112–124.
- Ningrum, S., Monoarfa, M. A. S., & Juanna, A. (2023). Pengaruh Digital Marketing Dan Daya Tarik Wisata Terhadap Minat Jumlah Kunjungan Wisatawan Mancanegara di Indonesia dan Wisatawan Nusantara di Provinsi Gorontalo Tahun 2018 - 2021. *JAMBURA Jurnal Ilmiah Manajemen Dan Bisnis*, 6(1), 225–241.

- Panduputri, T. U., & Novani, S. (2021). Examining Experience Economy Dimensions on Virtual Tour Satisfaction and Destination Visit Intention. *Journal of Integrated System*, 4(2), 101–114. <https://doi.org/10.28932/jis.v4i2.4155>
- Peng, J., Strijker, D., & Wu, Q. (2020). Place Identity: How Far Have We Come in Exploring Its Meanings? *Frontiers in Psychology*, 11(March), 1–19. <https://doi.org/10.3389/fpsyg.2020.00294>
- Ramadhanty, G., Setianti, Y., & Warta, W. (2024). Analisis City Branding Kota Cirebon Sebagai Culture-Based Tourism City. *Citizen: Jurnal Ilmiah Multidisiplin Indonesia*, 4(3), 205–217. <https://doi.org/10.53866/jimi.v4i3.610>
- Ramdan, M. R., Musadieg, M. Al, Yulianto, E., & Pangestuti, E. (2025). The Impact of E-WOM Social Media in Influencing Destination Image and Visit Intention in the Context of Tourism Industry: An Empirical Investigation of Social Media Enterprise Instagram Followers in Malang Raya, East Java. *Formosa Journal of Multidisciplinary Research*, 4(3), 1257–1272. <https://doi.org/10.55927/fjmr.v4i3.117>
- Ramkissoon, H. (2023). *Acta Psychologica Tourist behaviour: The role of digital marketing and social media* Baris. 240(June). <https://doi.org/10.1016/j.actpsy.2023.104025>
- Risda, & Candraningrat. (2025). STRATEGI PEMASARAN DIGITAL UNTUK MENINGKATKAN DAYA SAING DESTINASI PARIWISATA MELALUI MEDIA SOSIAL (STUDI KASUS PANTAI TANJUNG JUMLAI) Risda Universitas Dinamika. *Jurnal Rumpun Manajemen Dan Ekonomi*, 2(4), 215–226. <https://doi.org/10.61722/jrme.v2i4.5564>
- Rodrigues, S., Correia, R., Gonçalves, R., Branco, F., & Martins, J. (2023). Digital Marketing's Impact on Rural Destinations' Image, Intention to Visit, and Destination Sustainability. *Sustainability (Switzerland)*, 15(3), 1–20. <https://doi.org/10.3390/su15032683>
- Saraswati, A. I., Rizqia, Z. N., Kurniawati, L., & Fauzan, F. (2025). The Optimization of Digital Marketing Strategy for Tourist Destination in Ciliang Village, Pangandaran. *ICEETE Conference Series*, 3(1), 112–119. <https://doi.org/10.36728/iceete.v3i1.237>
- Sharafuddin, M., Madhavan, M., & Wangtueai, S. (2024). Evaluación de la eficacia del marketing digital para mejorar las experiencias y la satisfacción de los turistas un estudio sobre los servicios turísticos de Tailandia. *Administrative Sciences*, 14(11), 14–273. <https://doi.org/10.3390/admsci14110273>
- Sugiyono. (2013). No Title.
- Suraya Mansur1, A. M. 1Institut. (2024). Strategi Komunikasi dalam mempromosikan City Branding Yogyakarta Sebagai Kota Hanacaraka. *JURNAL KOMUNIKASI PROFESIONAL*, 8(2), 223–237.
- Yang, T., Ye, M., Pei, P., Shi, Y., & Pan, H. (2019). City branding evaluation as a tool for sustainable urban growth: A framework and lessons from the Yangtze River Delta Region. *Sustainability (Switzerland)*, 11(16). <https://doi.org/10.3390/su11164281>